

(No Model.)

B. B. ALLEN.  
REAMER.

No. 456,462.

Patented July 21, 1891.

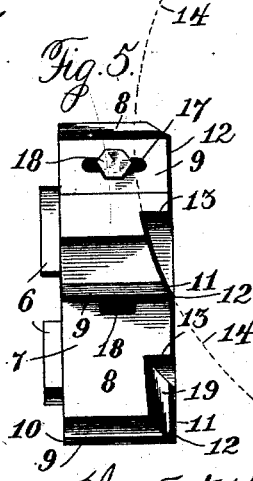
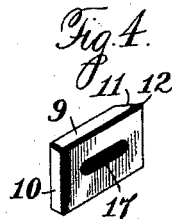
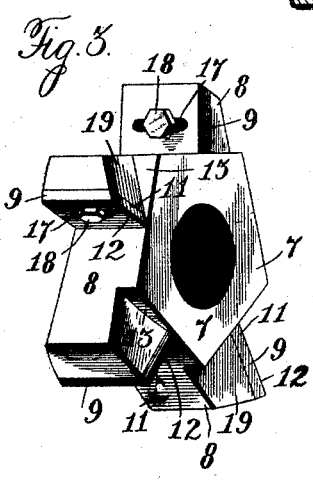
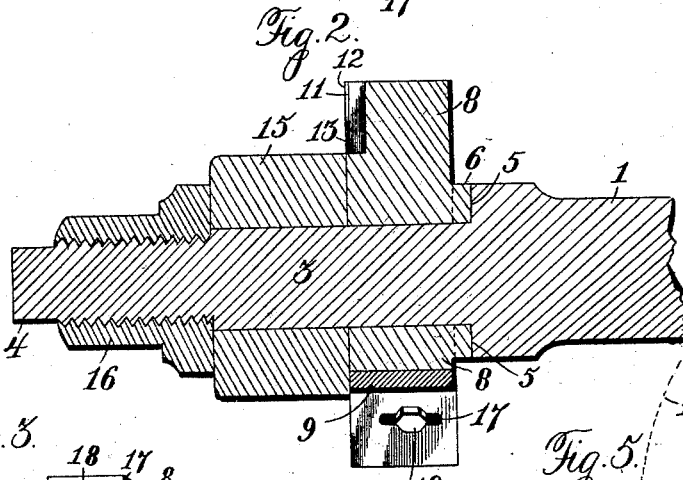
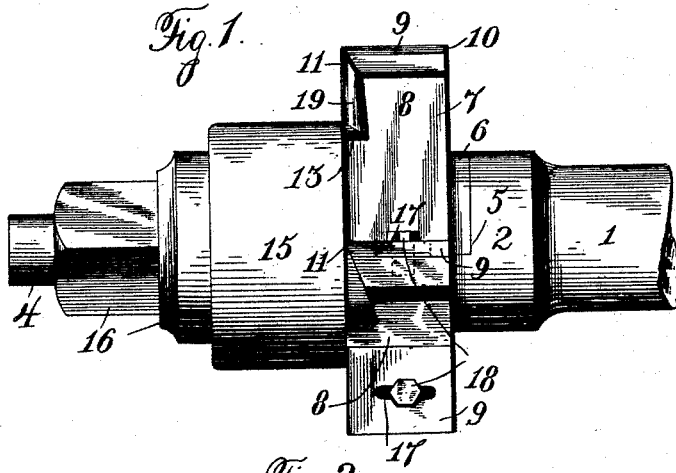

Witnesses:

*James Hutchinson*  
*J. A. Rutherford*

*Inventor*  
*Benjamin B. Allen*  
*By James L. Norris, Attorney*

# UNITED STATES PATENT OFFICE.

BENJAMIN B. ALLEN, OF NASHVILLE, TENNESSEE.

## REAMER.

SPECIFICATION forming part of Letters Patent No. 456,462, dated July 21, 1891.

Application filed May 22, 1891. Serial No. 393,705. (No model.)

*To all whom it may concern:*

Be it known that I, BENJAMIN B. ALLEN, a citizen of the United States, residing at Nashville, in the county of Davidson and State of Tennessee, have invented new and useful Improvements in Reamers, of which the following is a specification.

This invention relates to the reamer for which Letters Patent No. 450,879 were issued to me April 21, 1891, wherein a manifold-toothed cutter has each tooth formed with a rectilinear face coincident with the axis of the reamer and a beveled acting end running backward at an acute angle to the face to form a rectilinear cutting-edge arranged substantially at right angles to the axis of the reamer for enabling the teeth to be ground through the medium of an ordinary circular grindstone. In this former construction the diameter of the cutter remains invariable, notwithstanding frequent grindings to sharpen the teeth; but the thickness of the cutter relatively to the length of its teeth becomes reduced by resharpening, thereby varying what may be termed the "length" of the cutting-teeth. This may in a measure be found objectionable, and to avoid any such objection and to compensate for wear of the cutting-teeth incident to regrinding their beveled front ends is the object of my present invention.

To such end this invention consists in a reamer comprising a manifold-toothed cutter having each tooth adjustable longitudinally in a plane parallel with the longitudinal axis of the reamer-mandrel and formed with a rectilinear face coincident with the axis of the reamer, and a beveled front end running backward at an acute angle to the face to form a rectilinear cutting-edge arranged substantially at right angles to the axis of the reamer for the purpose of compensating for wear, while enabling the teeth to be ground on an ordinary grindstone without reducing the diameter of the cutter.

The invention is illustrated by the accompanying drawings, in which—

Figure 1 is a side elevation of a reamer constructed in accordance with my invention. Fig. 2 is a longitudinal sectional view of the same. Fig. 3 is a detail perspective view looking at the front end of the cutter. Fig.

4 is a detail view of one of the adjustable cutting-teeth. Fig. 5 is a diagram illustrating the manner of grinding the front face of a cutter-tooth.

In order to enable those skilled in the art to make and use my invention, I will now describe the same in detail, referring to the drawings, wherein—

The numeral 1 indicates the mandrel of the reamer, having a collar 2 and a shank 3, which is truly cylindrical and terminates at its extremity in a screw-threaded stem 4. The front face of the collar is formed with cavities 5 to receive and interlock with the shoulders 6, formed with and projecting from the rear face of the manifold-toothed cutter 7, whereby the cutter is not only compelled to rotate with the mandrel, but the weakest part of the cutter resulting from the bore therein to receive the cylindrical shank 3 is relieved of strain and the cutter is made substantially as strong as though it were an integral part of the mandrel.

I have shown the cutter-body as formed integral with a series of five radial teeth-seats 8; but more or less may be employed, so long as a sufficient number is provided for a set of teeth which will cut a true circular bore when the cutter is revolved for enlarging the hole in a shaft-boxing after the sand has been removed from the latter. The independent adjustable steel teeth 9 are each formed with a rectilinear face 10 and a beveled or oblique front end 11, which runs backward at an acute angle to the face 10 of the tooth, the construction being such that a rectilinear cutting-edge 12 is produced, which is radial and extends at right angles to the longitudinal axis of the mandrel.

The rectilinear faces 10 of the adjustable teeth are all coincident with the longitudinal axis or center of the cutter and of the mandrel, and since the front ends of the teeth are oblique or beveled and extend backward or rearward at acute angles to the faces of the teeth it is possible to conveniently, rapidly, and efficiently sharpen the cutter through the medium of an ordinary circular grindstone 14, in the manner indicated by dotted lines in Fig. 5 and as disclosed in my Letters Patent hereinbefore alluded to.

By the means described the cutting-edge of

the tool can be readily sharpened by means of an ordinary circular grindstone without in the least reducing the diameter of the tool, and consequently, although the cutting-edge  
 5 may become worn away from constant use, the diameter of the cutter as a whole remains unchanged.

The frequent regrinding of the cutter will reduce its thickness by shortening the cutter-teeth 9; but as they are lengthwise adjustable on the teeth-seats 8 in a plane parallel with the longitudinal axis of the reamer-mandrel it is possible to compensate for any reduction in the thickness of the cutter incident to  
 15 wearing of the cutter-teeth.

To adjust the teeth I provide each one with a longitudinal slot 17, extending in a plane parallel with the longitudinal axis of the mandrel, and through each slot I pass a set-screw  
 20 or bolt 18, which is tapped into a tooth-seat 8.

To render the cutter-teeth susceptible of being reground and sharpened while in position on the teeth-seats 8, the latter are formed with beveled or oblique front ends 19 in alignment with the beveled or oblique front ends  
 25 11 of the cutter-teeth, thereby producing offsets or shoulders 13, which constitute guides or supports for the grindstone while grinding the beveled ends of the cutter-teeth.

The cylindrical shank 3 of the mandrel is of such length as to support the cutter and also receive and sustain a guide 15, which is adapted to enter the hole to be enlarged and maintain the cutter in a central position.  
 35 This guide is formed as the section of a true cylinder, and with the cutter can be removed and replaced at will. The screw-stem of the shank is provided with a screw-nut 16, by which to clamp the guide against the cutter  
 40 and hold the latter in interlocking engagement with the collar 2 of the mandrel. This construction provides a strong, substantial, and durable reamer, which is particularly designed for finishing the brass boxes for shaft-  
 45 ing after the sand has been removed from the castings, the holes or orifices in the castings

being made to fit the guide 15, which is immediately in front of the manifold-toothed cutter. The improved cutter will enlarge  
 50 many holes or orifices of exactly the same diameter without corrugating the surfaces of the bores, as is done by the present reamer and lathe-tool ordinarily employed in finishing brass boxes for shafting.

The construction of the cutter is such that  
 55 by giving the teeth the requisite rake it can be used for cutting any material, including wood.

The cutter is made removable and replaceable for the purpose of enabling any one of  
 60 a series of cutters to be used on the mandrel for the purpose of cutting holes of different diameters, while permitting a cutter if broken to be promptly replaced at a small expense.

The reamer is useful for boring the boxes  
 65 of shafting, but obviously can be employed for any purpose where a hole is to be bored in metal or other material. The invention will be found well adapted for boring cannon, and the adjustability of the cutting-teeth  
 70 renders the device susceptible of boring holes of varying diameter.

Having thus described my invention, what I claim is—

A reamer comprising a manifold-toothed  
 75 cutter having each tooth adjustable longitudinally in a plane parallel with the axis of the reamer-mandrel and formed with a rectilinear face and a beveled front end running  
 80 backward at an acute angle to the face to form a rectilinear cutting-edge arranged substantially at right angles to the axis of the reamer for enabling the teeth to be adjusted and ground by an ordinary grindstone without reducing the diameter of the cutter. 85

In testimony whereof I have hereunto set my hand and affixed my seal in presence of two subscribing witnesses.

BENJAMIN B. ALLEN. [L. s.]

Witnesses:  
 E. B. DU VAL,  
 W. T. WALKER.